

**SERIES:** CFM-120B | **DESCRIPTION:** DC AXIAL FAN**FEATURES**

- dual ball bearing
- 120 x 120 mm frame
- multiple speed options
- tachometer signal available
- auto restart



MODEL	input voltage		input current <sup>1</sup>	input power <sup>1</sup>	rated speed <sup>1</sup>	airflow <sup>2</sup>	static pressure <sup>3</sup>	noise <sup>4</sup>
	rated (Vdc)	range (Vdc)	max (A)	max (W)	typ (RPM±10%)	(CFM)	(inch H <sub>2</sub> O)	typ (dBA)
CFM-A225B-015-287	5	4.5~5.5	0.24	1.20	1,500 <sup>5</sup>	52.31	0.06	24.8
CFM-A225B-018-327	5	4.5~5.5	0.45	2.25	1,800 <sup>5</sup>	62.77	0.09	28.8
CFM-A225B-020-350	5	4.5~5.5	0.57	2.85	2,000 <sup>5</sup>	69.74	0.10	37.8
CFM-A225B-115-287	12	10.8~13.2	0.11	2.76	1,500 <sup>5</sup>	52.31	0.06	24.8
CFM-A225B-120-350	12	10.8~13.2	0.23	2.76	2,000 <sup>5</sup>	69.74	0.10	37.8
CFM-A225B-125-398	12	10.8~13.2	0.41	4.92	2,500	87.18	0.13	42.7
CFM-A225B-220-350	24	21.6~26.4	0.17	4.08	2,000 <sup>5</sup>	69.74	0.10	37.8
CFM-A225B-230-438	24	21.6~26.4	0.30	7.20	3,000	104.62	0.21	46.6
CFM-A238B-126-435	12	10.8~13.2	0.48	5.76	2,600	100.71	0.24	43.5
CFM-A238B-132-480	12	10.8~13.2	0.86	10.32	3,200	123.71	0.34	48.0
CFM-A238B-138-529	12	10.8~13.2	1.10	13.20	3,800	146.90	0.48	53.0
CFM-A238B-226-435	24	21.6~26.4	0.27	6.48	2,600	100.71	0.24	43.5
CFM-A238B-232-480	24	21.6~26.4	0.53	12.72	3,200	123.71	0.34	48.0
CFM-A238B-238-529	24	21.6~26.4	0.58	13.92	3,800	146.90	0.48	53.0

- Notes:
1. At rated voltage, after 3 minutes.
  2. At rated voltage, room temperature, 65% humidity, 0 inch H<sub>2</sub>O static pressure.
  3. At rated voltage, 0 CFM airflow.
  4. Measured in an anechoic chamber as per ISO3745/GB4214-84 at rated voltage, with background noise 20±2 dBA at 1 m from the fan intake.
  5. Typical rated speed is measured as RPM±250 at rated voltage.
  6. All specifications are measured at 25°C, 65% relative humidity unless otherwise specified.

**PART NUMBER KEY****CFM-A225B-015-287 - XX - CXX**

Base Number

Fan Signals  
"blank" = no signals  
20 = tachometer signalReserved for Custom  
Configurations

## INPUT

parameter	conditions/description	min	typ	max	units
operating input voltage <sup>7</sup>	5 Vdc input models	4.5	5	5.5	Vdc
	12 Vdc input models	10.8	12	13.2	Vdc
	24 Vdc input models	21.6	24	26.4	Vdc
starting voltage	5 Vdc input models		4.0		Vdc
	12 Vdc input models		7.0		Vdc
	24 Vdc input models		14.0		Vdc

Note: 7. See Model section on page 1 for specific input voltage ranges.

## PERFORMANCE<sup>8</sup>

parameter	conditions/description	min	typ	max	units
rated speed	at rated voltage, 25°C, after 3 minutes	1,500		3,800	RPM
air flow	at 0 inch H <sub>2</sub> O, see performance curves	52.31		146.90	CFM
static pressure	at 0 CFM, see performance curves	0.06		0.48	inch H <sub>2</sub> O
noise	at 1 m, rated speed	24.8		53.0	dBA

Note: 8. See Model section on page 1 for specific values.

## PROTECTIONS / FEATURES<sup>9</sup>

parameter	conditions/description	min	typ	max	units
auto restart	on all models				
polarity protection	on all models				
tachometer signal	available on "20" models				

Notes: 9. See Application Notes for details.

## SAFETY & COMPLIANCE

parameter	conditions/description	min	typ	max	units
insulation resistance	at 500 Vdc between frame and positive terminal	10			MΩ
dielectric strength	at 500 Vac, 60 Hz, 1 minute between housing and positive terminal			5	mA
safety approvals	UL/cUL 507, TUV (EN/IEC 62368-1:2020+A11)				
EMI/EMC	EN 55032:2015, EN 55035:2017				
life expectancy	at 40°C, 65% RH, 90% confidence level		70,000		hours
RoHS	yes				

## ENVIRONMENTAL

parameter	conditions/description	min	typ	max	units
operating temperature		-10		70	°C
storage temperature		-40		75	°C
operating humidity	non-condensing	35		85	%
storage humidity	non-condensing	35		85	%

## PERFORMANCE CURVES

**CFM-A225B-015-287**

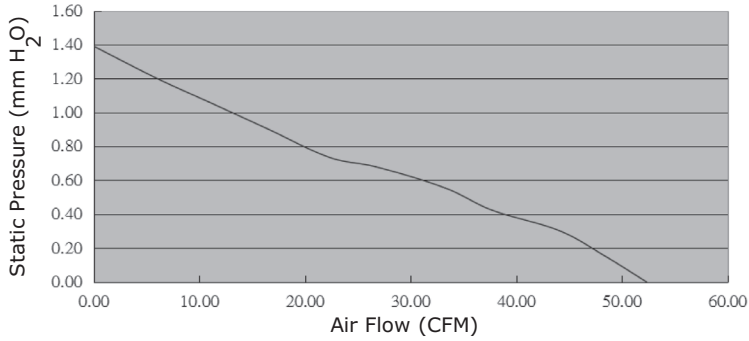

**CFM-A225B-018-327**

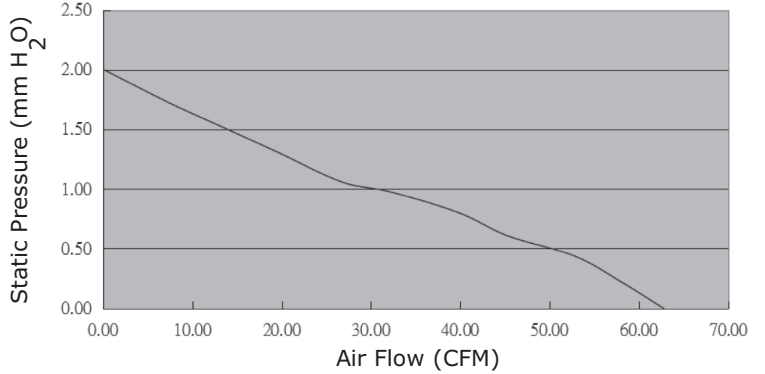

**CFM-A225B-020-350**

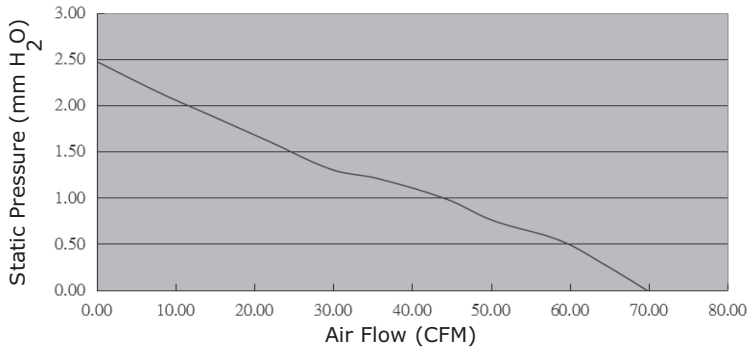

**CFM-A225B-115-287**

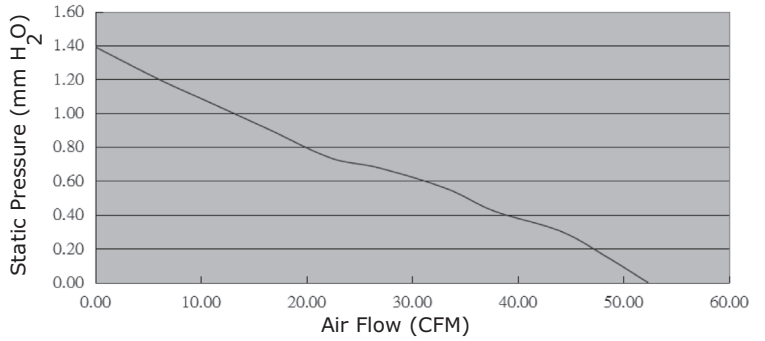

**CFM-A225B-120-350**

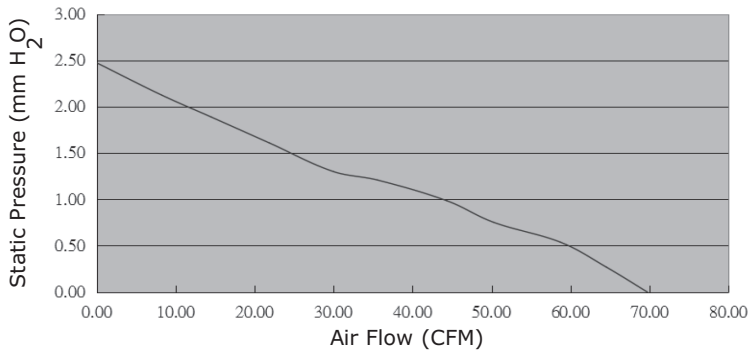

**CFM-A225B-125-398**

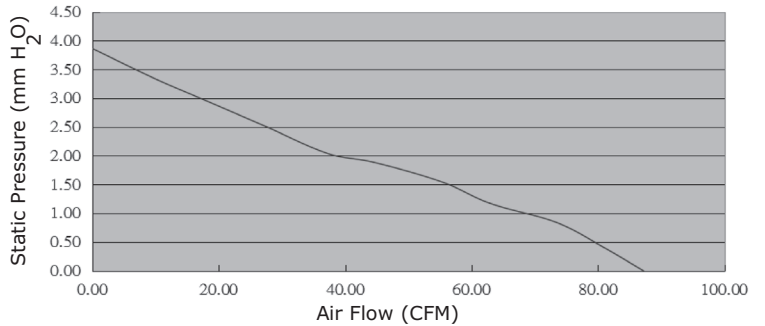

## PERFORMANCE CURVES (CONTINUED)

**CFM-A225B-220-350**

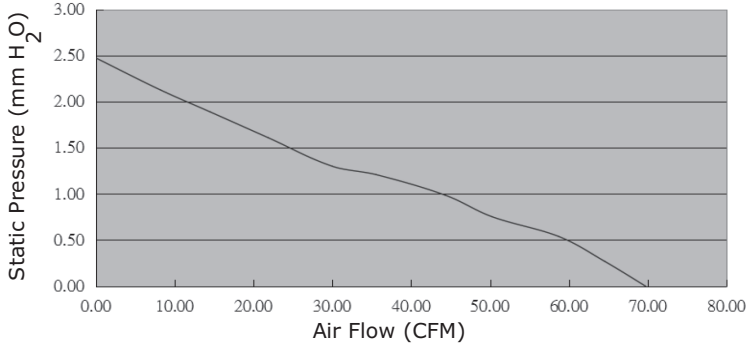

**CFM-A225B-230-438**

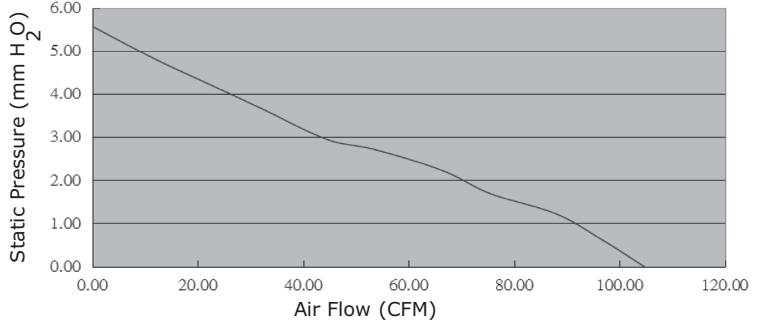

**CFM-A238B-126-435**

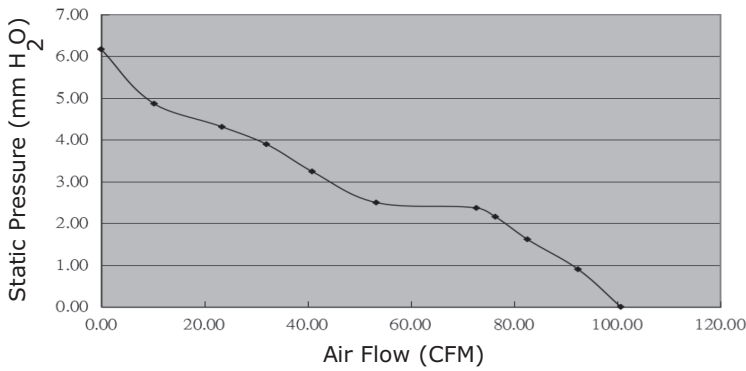

**CFM-A238B-132-480**

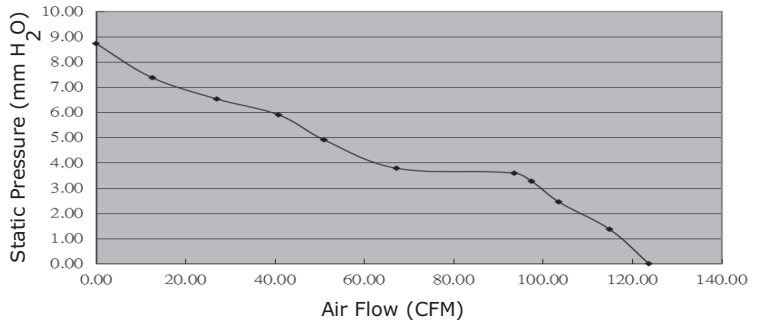

**CFM-A238B-138-529**

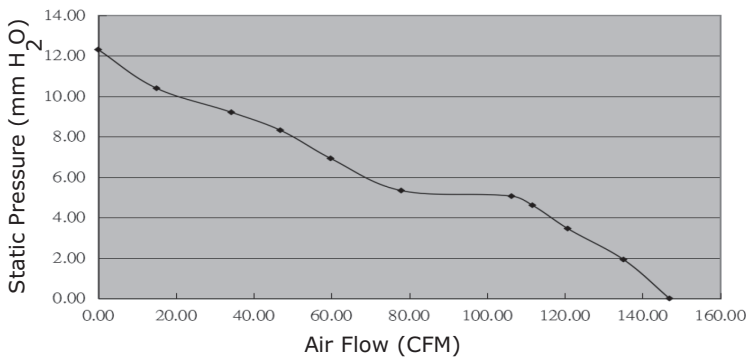

**CFM-A238B-226-435**

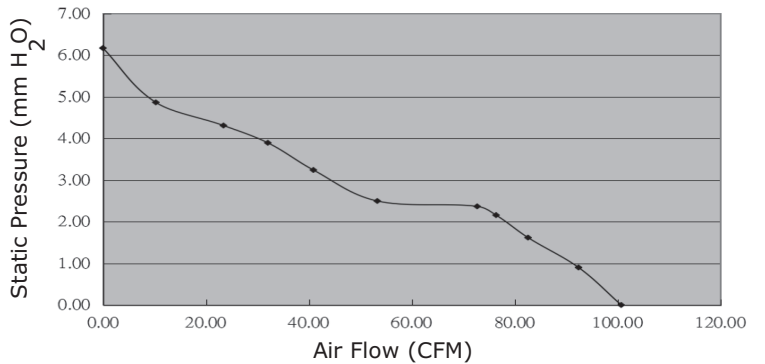

## PERFORMANCE CURVES (CONTINUED)

**CFM-A238B-232-480**

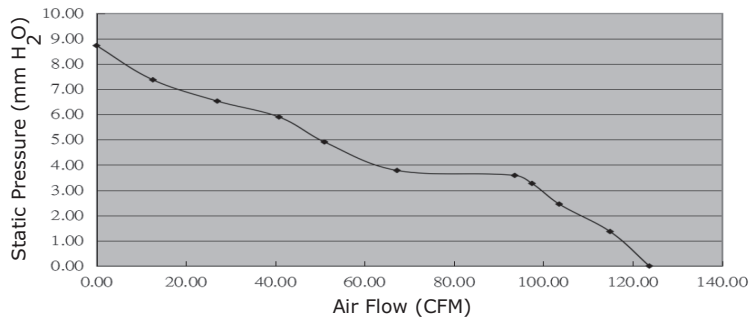

**CFM-A238B-238-529**

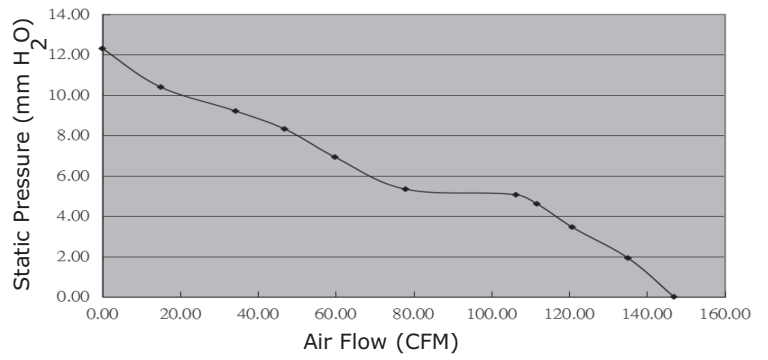

## MECHANICAL

parameter	conditions/description	min	typ	max	units
motor	4 pole DC brushless				
bearing system	dual ball bearing				
direction of rotation	counter-clockwise viewed from front of fan blade				
dimensions	CFM-A225B models: 120 x 120 x 25.4 CFM-A238B models: 120x 120 x 37.5				mm mm
material	PBT (UL94V-0)				
weight	CFM-A225B models CFM-A238B models		83.9 300		g g

## MECHANICAL DRAWING

units: mm

wire: UL 1007, 24 AWG

MOUNTING SCREW (Pan Head)			
Screw Type	Size	Standard	Torque
Machine Screw	M4	JIS B1111-1974	4.5 kgf-cm
Self-tapping Screw	M5	JIS B1122 Type 2	5.5 kgf-cm

### CFM-A225B

WIRE CONNECTIONS	
Wire Color	Function
Red	+Vin
Black	-Vin
Yellow <sup>10</sup>	Tach Signal

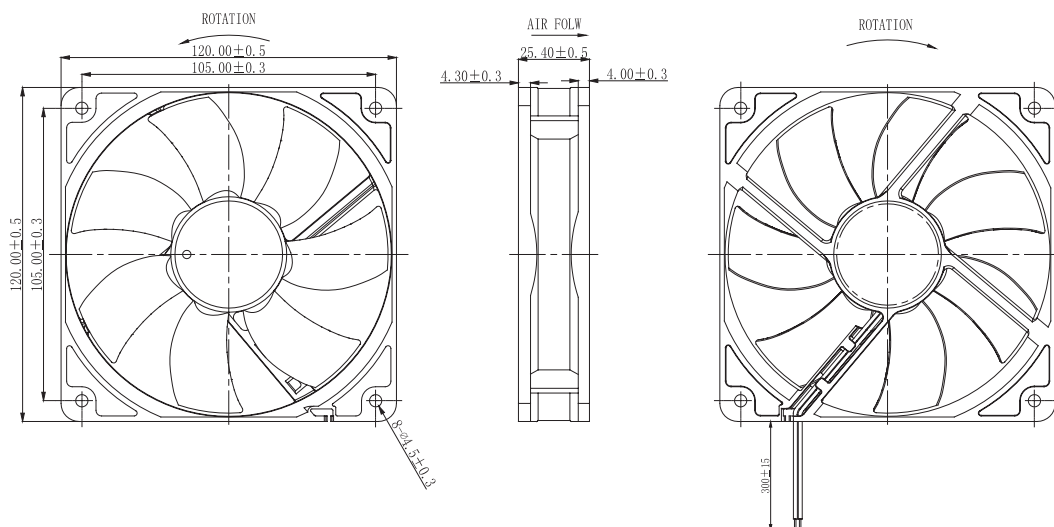

Notes: 10. Wires only present on versions with output signals.

## MECHANICAL DRAWING (CONTINUED)

units: mm

wire: UL 1007, 24 AWG

### CFM-A238B

WIRE CONNECTIONS	
Wire Color	Function
Red	+Vin
Black	-Vin
Yellow <sup>10</sup>	Tach Signal

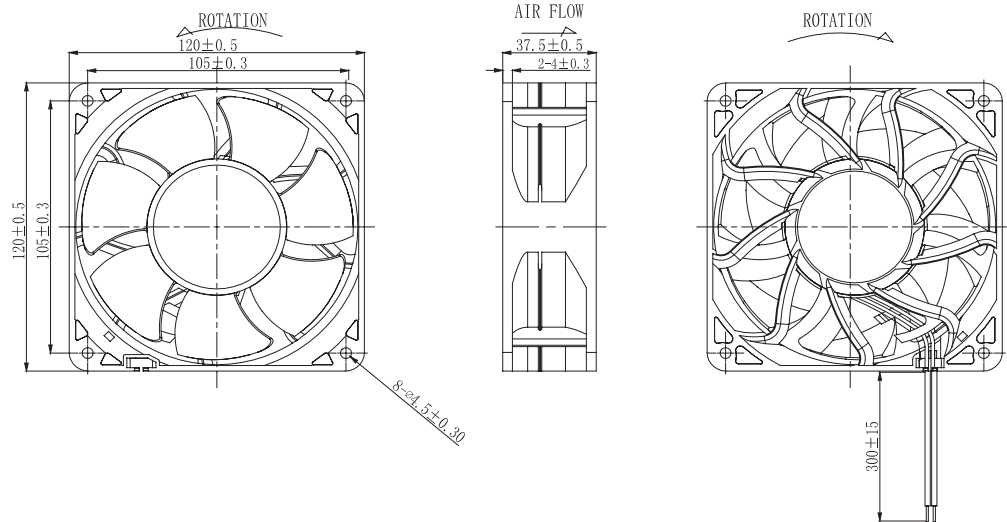

MOUNTING SCREW (Pan Head)			
Screw Type	Size	Standard	Torque
Machine Screw	M4	JIS B1111-1974	4.5 kgf-cm
Self-tapping Screw	M5	JIS B1122 Type 2	5.5 kgf-cm

Notes: 10. Wires only present on versions with output signals.

## APPLICATION NOTES

### Auto Restart Protection

When the fan motor is locked by an external force, the device will temporarily turn off electrical power to the motor and restart automatically when the locked rotor condition is released.

### Polarity Protection

Able to withstand 10 minutes of reverse polarity connection between the positive and negative wires without causing damage.

### Tachometer Signal (Yellow Wire)

The tachometer signal is for detecting the rotational speed of the fan motor. The output will be a square wave when fan is operating and V<sub>FG</sub> or V<sub>CE</sub> depending on the locked rotor position when fan motor is locked (See Figures 1~2 below).

**Figure 1: Tachometer Output Circuit**

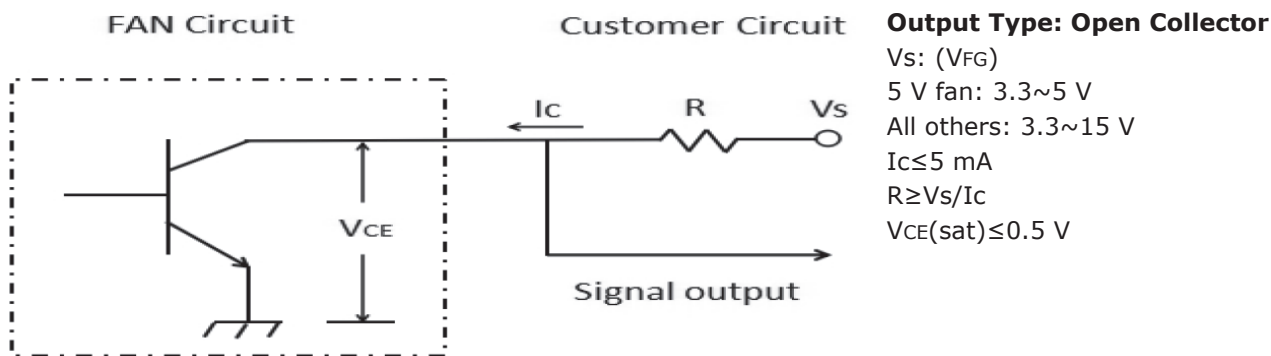

**Figure 2: Tachometer Output Waveform**

