

## Labeling with KLM Plotter Marking for Terminal Blocks

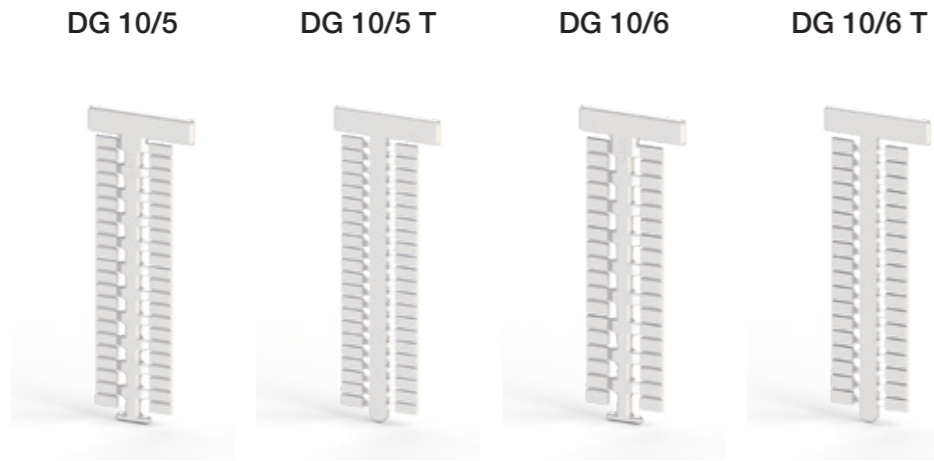

General Features				
Cat. No.	505 310	505 380	505 320	505 390
Dimensions	10 x 5	10 x 5	10 x 6	10 x 6
Quantity	440	440	360	360
Plotter Plate	PLOT PL - A	PLOT PL - A	PLOT PL - A	PLOT PL - A

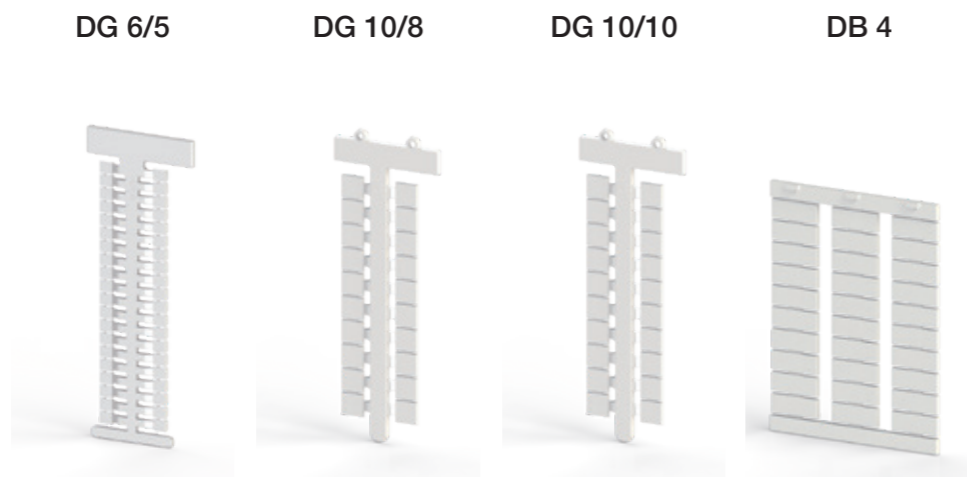

General Features				
Cat. No.	505 330	505 410	505 430	503 000
Dimensions	6 x 5	10 x 8	10 x 10	10 x 4
Quantity	400	260	200	500
Plotter Plate	PLOT PL - A	PLOT PL - A	PLOT PL - A	PLOT PL - DB 4

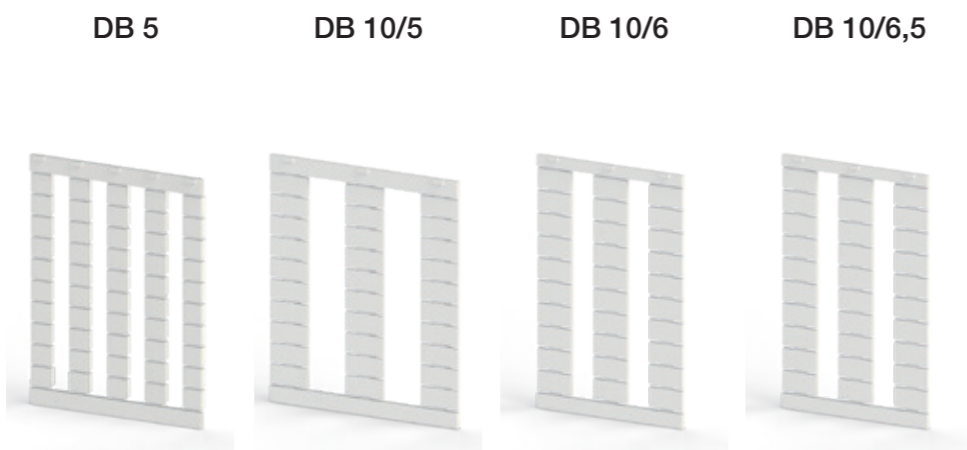

General Features				
Cat. No.	505 850	505 910	505 915	505 920
Dimensions	5 x 5	10 x 5	10 x 6	10 x 6,5
Quantity	500	500	500	500
Plotter Plate	PLOT PL - DB 5	PLOT PL - DB	PLOT PL - DB	PLOT PL - DB

## Labeling with KL-Tx300 Marking for Terminal Blocks



Cat. No.	Product	Size	Color	Qty.
1020 100	SLF - P1 W	11,2 mm x15 m	White	1
1020 110	SLF - P2 W	4,9 mmx15 m	White	1

- Strip labels provide a higher surface gloss as thermal process brings long-lasting marking solutions.
- High degree of tear resistance and tear propagation resistance.
- Good ageing stability, waterproof.
- This product resists water, chemicals, grease and oils.

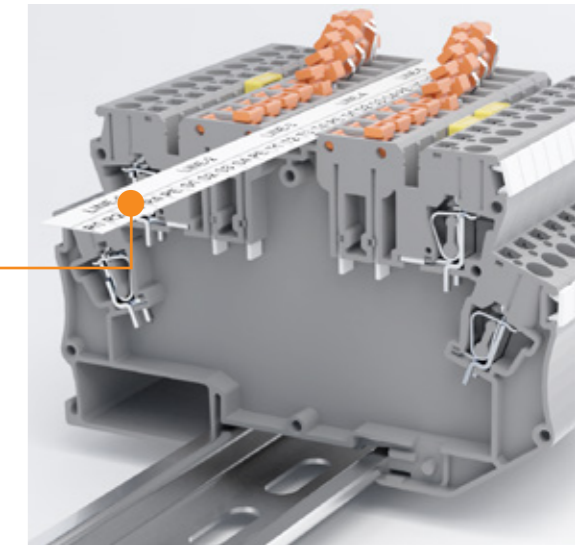
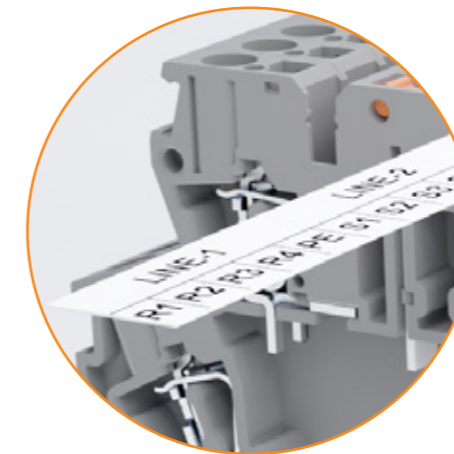

## Labeling with KLECARD Marking for Terminal Blocks

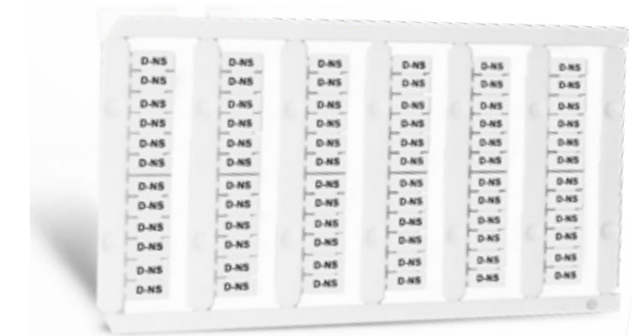
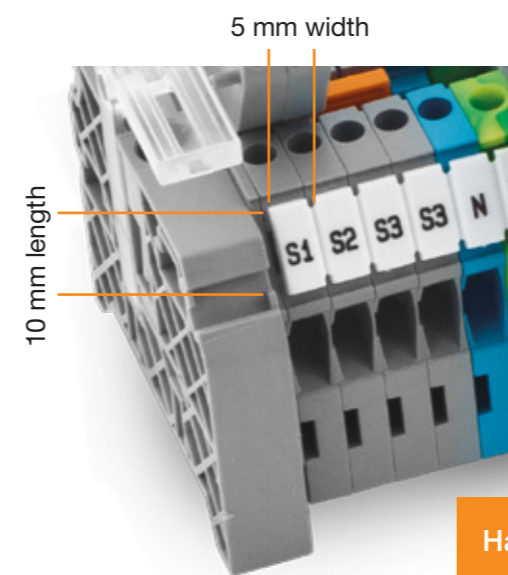

Halogen Free VO raw material

Cat. No.	Product	Print Area (mm)	Color	Labels per Card	Cards per Pack
811 750	D-NS 5x10 Tags	5x10	White	72	10
812 250	D-NS 6x10 Tags	6x10	White	60	10
810 300	D-NS 5x6 Tags	5x6	White	72	10
810 450	D-NS 5,2x6 Tags	5,2x6	White	72	10
812 750	D-NS 8x10 Tags	8x10	White	48	10
813 100	D-NS 10x10 Tags	10x10	White	36	10